

INSTRUCTION MANUAL YSI MODELS 54ARC AND 54ABP DISSOLVED OXYGEN METERS

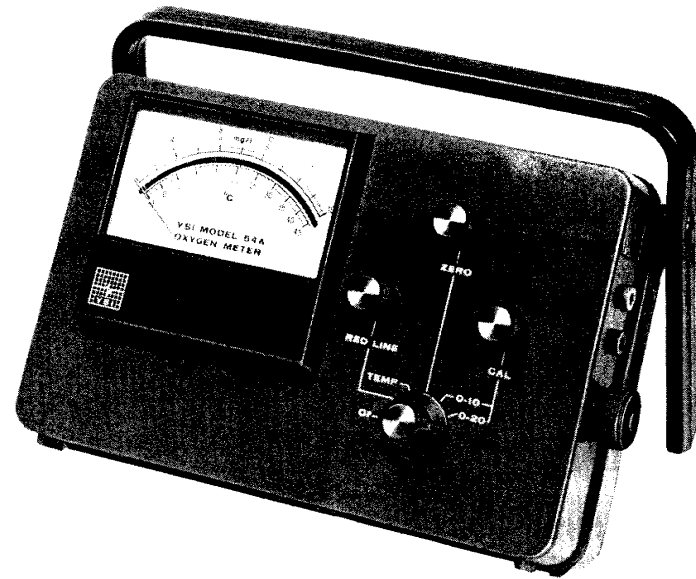

YSI Incorporated

Yellow Springs Instrument Co., Inc., Yellow Springs, Ohio 45387 USA
Phone 513 767-7241 • 800 343-HELP • Fax 513 767-9353 • Telex 205437

SUMMARY OF OPERATING INSTRUCTIONS

1. CALIBRATION

- A. Switch instrument to OFF and adjust meter mechanical zero.
- B. Switch to RED LINE and adjust.
- C. Prepare probe for operation, connect to instrument, wait up to 15 minutes for probe to stabilize. Probe can be in calibration chamber or ambient air.
- D. Switch to ZERO and adjust to "0" on mg/l scale.
- E. Switch to TEMP and read on °C scale.
- F. Use probe temperature and true local atmospheric pressure (or feet above sea level) to determine calibration values from Tables I and II. (See pages 14 and 15).

EXAMPLE: Probe temperature = 21°C; Altitude = 1000 feet. From Table I the calibration value for 21°C is 8.9 mg/l. From Table II the altitude factor for 1000 feet is approximately .96. The correct calibration value, then, is:

$$8.9 \text{ mg/l} \times .96 \text{ factor} = 8.54 \text{ mg/l}$$

- G. Switch to 0-10 or 0-20 mg/l range and adjust meter with CAL control to calibration value determined in Step F.

NOTE: It is desirable to calibrate probe in a high humidity environment. (See calibration section for more detail).

2. MEASUREMENT

- A. Place probe in sample and stir.
- B. Allow sufficient time for probe to stabilize to sample temperature and dissolved oxygen.
- C. Read dissolved oxygen on appropriate range (1-10 or 0-20 mg/l)
- D. We recommend the instrument be left on between measurements to avoid the necessity to repolarize the probe.

3. GENERAL CARE

- A. Recharge batteries in the YSI Model 54ARC when the instrument can no longer be red lined. Recharge 16-20 hours. Replace with Burgess CD-6 or equivalent. Replace batteries in the YSI Model 54ABP when red line cannot be set with Panasonic UM-2N or equivalent.
- B. Membranes will last indefinitely, depending on usage. Average replacement is 2-4 weeks. Probe should be stored in humid environment to prevent drying out.
- C. Calibrate daily.

TABLE OF CONTENTS

	<i>Page</i>
GENERAL DESCRIPTION	2
SPECIFICATIONS	
I. Instrument	3
II. Probe	3
III. Accessories and Replacement Parts	4
OXYGEN PROBES AND EQUIPMENT	
I. YSI 5739 D.O. Probe	4
II. YSI 5720A B.O.D. Bottle Probe	5
III. YSI 5750 B.O.D. Bottle Probe	7
IV. Cable Adaptors	7
V. YSI 5791A and 5795A Submersible Stirrers	7
VI. YSI 5721 Battery Pack	8
OPERATING PROCEDURES	
I. Preparing the Probe	8
II. Preparing the Instrument	10
III. Calibration	10
IV. Dissolved Oxygen Measurement	13
V. High Sensitivity Membrane	13
VI. Recorder Output	13
VII. Calibration Tables	15
DISCUSSION OF MEASUREMENT ERRORS	18
INSTRUMENT BATTERIES	19
WARRANTY AND REPAIR	20
SCHEMATIC DIAGRAM	CENTER SPREAD

GENERAL DESCRIPTION

The YSI Models 54ARC and 54ABP Dissolved Oxygen Meters are intended for dissolved oxygen and temperature measurement in water and wastewater applications, but are also suitable for use in certain other liquids. Dissolved Oxygen is indicated in mg/l (milligrams per liter) on 0-10 and 0-20 mg/l scales. Temperature is indicated in °C on a -5° to +45°C scale. Both dissolved oxygen ranges are automatically temperature compensated for solubility of oxygen in water and permeability of the probe membrane.

The probes use Clark-type membrane covered polarographic sensors with built-in thermistors for temperature measurement and compensation. A thin, permeable membrane stretched over the sensor isolates the sensor elements from the environment, but allows oxygen and certain other gases to enter. When a polarizing voltage is applied across the sensor, oxygen that has passed through the membrane reacts at the cathode, causing a current to flow.

The membrane passes oxygen at a rate proportional to the pressure difference across it. Since oxygen is rapidly consumed at the cathode, it can be assumed that the oxygen pressure inside the membrane is zero. Hence, the force causing the oxygen to diffuse through the membrane is proportional to the absolute pressure of oxygen outside the membrane. If the oxygen pressure increases, more oxygen diffuses through the membrane and more current flows through the sensor. A lower pressure results in less current.

Power to operate the system is provided by internal batteries in the instruments, rechargeable batteries in the YSI Model 54ARC and disposable batteries in the YSI Model 54ABP.

SPECIFICATIONS

I. Instrument

Oxygen Measurement

Ranges: 0-10 and 0-20 mg/l (0-5 and 0-10 mg/l with YSI 5776 High Sensitivity Membrane)

Accuracy: ±1% of full scale at calibration temperature (±0.1 mg/l and 0-10 scale).

Readability: .05 mg/l on 0-10 scale; 0.1 mg/l on 0-20 scale.

Temperature Measurement

Ranges: -5° to +45°C

Accuracy: ±0.7°C, including probe

Readability: 0.25°C

Temperature Compensation

±1% of D.O. reading for measurements made within ±5°C of calibration temperature.

±3% of D.O. reading over entire range of -5 to +45°C Probe temperature.

System Response Time

Typical response for temperature and D.O. readings is 90% in 10 seconds at constant temperature of 30°C with YSI 5775 Membranes. D.O. response at low temperature and low D.O. is typically 90% in 30 seconds. YSI 5776 High Sensitivity Membranes can be used to improve response at

low temperature and low D.O. concentrations. If response time under any operating conditions exceeds two minutes, probe service is indicated.

Operating Temperature Range

Instrument and probe operating range is -2° to +45°C. Large ambient temperature changes will result in 2% loss of accuracy unless Red Line and Zero are reset.

Recorder Output

0 to 114-136 mV. Recorder should have 50,000 ohms minimum input impedance.

Power Supply

YSI Model 54ABP: (4) 1.5 volt carbon zinc batteries provide approximately 1000 hours operation. Replace with Panasonic UM-2N or equal.

YSI Model 54ARC: (4) 1.25 volt Ni-Cad rechargeable cells (Burgess CD-6 or equal) provide approximately 100 hours of operation between charges.

II. Probe

Cathode: Gold

Anode: Silver

Membrane: .001" FEP Teflon (.0005" FEP Teflon available)

Electrolyte: Half Saturated KCl

Temperature Compensation: (See SPECIFICATIONS, I. Instrument)

Pressure Compensation: Effective 1/2% of reading to pressures of 100 psi (230 ft. water)

Polarizing Voltage: 0.8 volts nominal

Probe Current: Air at 30°C = 19 microamps nominal

Nitrogen at 30°C = .15 microamps or less

III. Accessories and Replacement Parts

YSI 5720A — Self Stirring B.O.D. Bottle Probe

YSI 5750 — Non Stirring B.O.D. Bottle Probe

YSI 5739 — Oxygen Temperature Probe for field use. Combine with one of the following cables for desired lead length:

YSI 5401 — Battery Charger Eliminator 115V

YSI 5402 — Battery Charger Eliminator 230V

Detachable leads for use with YSI 5739:

YSI 5740-10 10' cable

YSI 5740-25 25' cable

YSI 5740-50 50' cable

YSI 5740-100 100' cable

YSI 5740-150 150' cable

YSI 5740-200 200' cable

YSI 5492A — Battery Pack Operates YSI 5791A and 5795A Submersible Stirrers

- YSI 5791A — Submersible Stirrer for field use
- YSI 5795A — Submersible Stirrer for field use
- YSI 5075A — Calibration Chamber for use with field probe
- YSI 3580 — Carrying Case
- YSI 5775 — Membrane and KCl Kit, Standard — includes 2 each 15-membrane packets (.001" thick standard membranes) and a 30 ml bottle KCl with Kodak Photo Flo.
- YSI 5776 — Membrane and KCl Kit, High Sensitivity — includes 2 each 15-membrane packets (.0005" thick membranes) and a 30 ml bottle KCl with Kodak Photo Flo.
- YSI 5945 — "O" Ring Pack — includes (6) "O" rings for each YSI D.O. Probe.
- YSI 5486 — Beater Boot Kit — includes (1) A-05486 Boot, (1) A-05484 Tip, (2) A-05485 Spring. Used only on 5720A and discontinued 5420A and 5720.
- YSI 5986 — Diaphragm Kit for use only with YSI 5739 D.O. Probe.
- YSI 5734 — Adaptor makes it possible to use discontinued YSI 5400 Series Probes with YSI Models 54ARC and 54ABP.

OXYGEN PROBES AND EQUIPMENT

There are three oxygen probes for use with the YSI Models 54ARC and 54ABP Dissolved Oxygen Meters. Descriptions of where they are used are contained in the following paragraphs.

I. YSI 5739 D.O. Probe

The YSI 5739 probe, with built-in lead weight and pressure compensation, is an improved design that replaces the discontinued YSI 5418, 5419, 5718 and 5719 probes. (See Figure 1)

For user convenience the probe is equipped with a disconnecting cable to facilitate changing cable lengths and replacing damaged cables or probes. The probe and cable assembly is held together with a threaded retaining nut. The connection is *not* designed for casual disconnection and should only be disconnected when necessary.

To disconnect the cable unscrew the retaining nut and slide it down the cable to expose the connector. Pull gently on the cable and connector until the connector comes away from the probe body.

To reassemble, inspect the connector and "O" ring for cleanliness. If the "O" ring is frayed or damaged remove it by squeezing it in the groove causing it to bulge, then roll it out of the groove and off the connector. A replacement "O" ring is supplied with the cable.

Push the connector into the probe body, rotating it until the two halves mate. A light coating of vaseline or silicone grease on the "O" ring will make reassembly easier. Air trapped between the connector halves which may cause them to spring apart slightly, is normal. Screw on the retaining nut, *hand tight only*. NOTE: If erratic readings are experienced, disconnect the cable and inspect for water. If present, dry out and reconnect, replacing the "O" ring, if necessary.

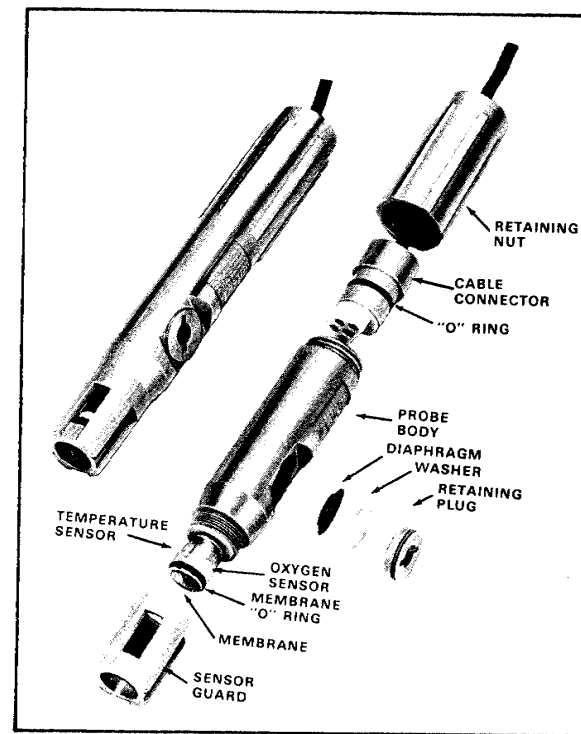

Figure 1

Pressure Compensation

The vent on the side of the probe is part of a unique pressure compensating system that helps assure accurate readings at great depths of water. Pressure compensation is effective to 1/2% of reading with pressures to 100 psi (230 ft. water). The quantity of air bubbles trapped under the membrane determines how serious the pressure error will be, which is why proper preparation of the probe is essential. (See OPERATING PROCEDURES.) The system is designed to accommodate a small amount of trapped air and still function properly, but the amount should be kept to a minimum.

The compensating system normally does not require servicing and should not be taken apart. However, if electrolyte is leaking through the diaphragm or if there is an obvious puncture, the diaphragm must be replaced. A spare is supplied with the probe. Using a coin unscrew the retaining plug and remove the washer and the diaphragm, flush any salt crystals from the reservoir, install the new diaphragm (convolution side in), replace the washer, and screw in the retaining plug.

II. YSI 5720A BOD Bottle Probe

The YSI 5720A BOD Bottle Probe replaces the discontinued YSI 5720A BOD Bottle Probe for measuring dissolved oxygen and temperature in standard BOD bottles. It is provided with an agitator for stirring the sample solution, and is available for operation with either 115 VAC (103 to 127 VAC) 60 Hz or 230 VAC (207 to 253 VAC) 50 Hz. See Figure 2.

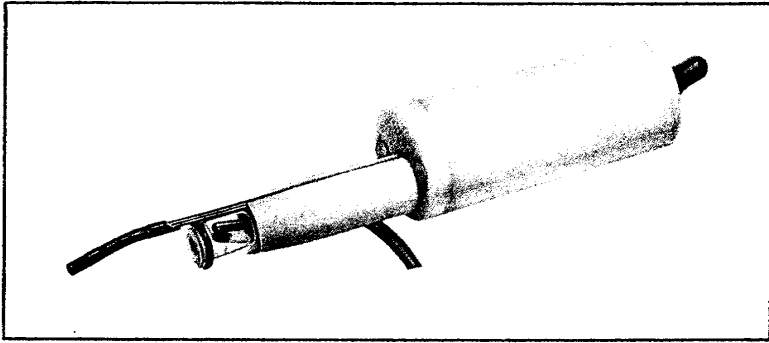

Figure 2

When using the probe, plug the agitator power supply into line power and the probe plug into the instrument. With the agitator turned off place the tapered probe end into the B.O.D. bottle and switch agitator "ON" with switch on top of probe. The probe should be operated with a minimum of trapped air in the B.O.D. bottle. A slight amount of air in the unstirred region at the top of the bottle may be neglected, but no bubbles should be around the thermistor or oxygen sensor.

Stirrer Boot

The probe uses a flexible stirring boot to transmit motion from the sealed motor housing to the sample. If the boot shows signs of cracking or other damage likely to allow leaking into the motor housing, the boot must be replaced.

In fresh water applications boot life is normally several years, but this may be shortened by exposure to hydrocarbons, moderate to strong acids or bases, ozone, or direct sunlight. For maximum life rinse the boot after use in contaminated samples. (See Figure 3)

Boot replacement is as follows:

1. Pull off old assembly and clean shaft.
2. Slide on new assembly making sure the back spring is on the grooved area of the shaft. A small amount of rubber cement may be used.
3. Check that there is sufficient clearance between the tip and the end of the shaft to permit turning without binding.

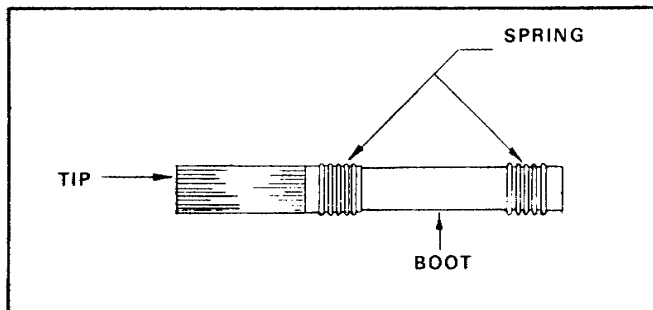

Figure 3

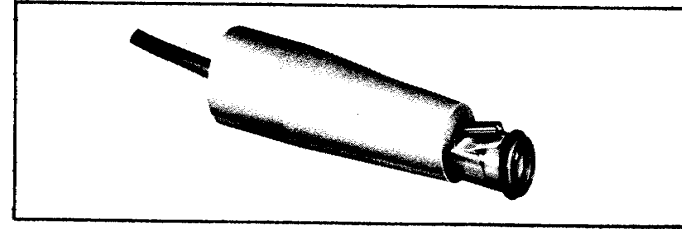

Figure 4

III. YSI 5750 B.O.D. Bottle Probe

The YSI 5750 B.O.D. Bottle Probe replaces the discontinued YSI 5450 B.O.D. Bottle Probe. It is similar to the YSI 5720A B.O.D. Bottle Probe, except that it does not have a stirrer. Agitation of the sample must be provided by other means, such as a magnetic stirrer. (See Figure 4)

IV. Cable Adaptors

All YSI 5700 Series Probes are designed for direct use with the YSI Models 54ARC and 54ABP Dissolved Oxygen Meters.

V. YSI 5791A and 5795A Submersible Stirrers

The YSI submersible stirrers are accessories that perform the function of stirring the sample being studied when making dissolved oxygen measurements in the field. The YSI 5791A stirrer can be used with the following dissolved oxygen probes: YSI 5418, 5419, 5718, 5719, and 5739. The YSI 5795A stirrer is only for use with the YSI 5739 Probe. (See Figure 5)

When a stirrer and probe are assembled, the stirrer agitates the sample directly in front of the sensor by means of a rotating eccentric weight which causes the spring-mounted hermetically sealed motor housing to vibrate. An impeller on the end of the motor housing flushes the media across the oxygen sensor. (See sales literature and instruction sheets for further information).

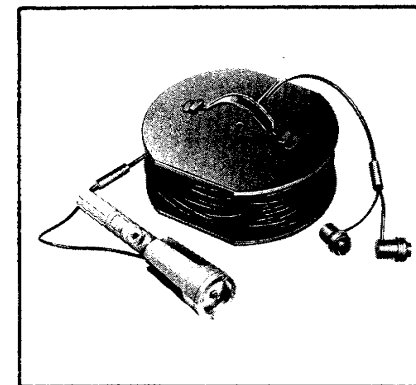

Figure 5

VI. YSI 5492A Battery Pack

The YSI 5492A Battery Pack is designed to attach to the case of all YSI Model 54 Dissolved Oxygen Meters to provide power for operating the submersible stirrers. (See sales literature and instruction sheets for further information).

OPERATING PROCEDURES

1. Preparing the Probe

All YSI 5700 Series Probes have similar sensors and should be cared for in the same manner. They are precision devices relying on good treatment if high accuracy measurements are to be made. Prepare the probes as follows. (See Figure 6)

ALL PROBES ARE SHIPPED DRY — YOU MUST FOLLOW THESE INSTRUCTIONS

1. Prepare the electrolyte by dissolving the KCl crystals in the dropper bottle with distilled water. Fill the bottle to the top.
2. Unscrew the sensor guard from the probe (YSI 5739 only) and then remove the "O" ring and membrane. Thoroughly rinse the sensor with KCl solution.
3. Fill the probe with electrolyte as follows:
 - A. Grasp the probe in your left hand. When preparing the YSI 5739 probe the pressure compensating vent should be to the right. Successively fill the sensor body with electrolyte while pumping the diaphragm with the eraser end of a pencil or similar soft, blunt tool. Continue filling and pumping until no more air bubbles appear. (With practice you can hold the probe and pump with one hand while filling with the other.) When preparing the YSI 5720A and 5750 probes, simply fill the sensor body until no more air bubbles appear.
 - B. Secure a membrane under your left thumb. Add more electrolyte to the probe until a large meniscus completely covers the gold cathode. NOTE: Handle membrane material with care, keeping it clean and dust free, touching it only at the ends.
 - C. With the thumb and forefinger of your other hand, grasp the free end of the membrane.
 - D. Using a continuous motion *stretch* the membrane *UP, OVER,* and *DOWN* the other side of the sensor. Stretching forms the membrane to the contour of the probe. The membrane can be stretched to approximately 1-1/2 times its normal length.
 - E. Secure the end of the membrane under the forefinger of the hand holding the probe.
 - F. Roll the "O" ring over the end of the probe. There should be no wrinkles in the membrane or trapped air bubbles. Some wrinkles may be removed by lightly tugging on the edges of the membrane beyond the "O" ring.
 - G. Trim off excess membrane with scissors or sharp knife. Check that the stainless steel temperature sensor is not covered by excess membrane.
4. Shake off excess KCl and reinstall the sensor guard.
5. A bottomless plastic bottle is provided with the YSI 5739 probe for convenient storage. Place a small piece of moist towel or sponge in the bottle and insert the probe into the open end. This keeps the electrolyte from dry-

ing out. The YSI 5720A and 5750 probes can be stored in a B.O.D. bottle containing about 1" of water.

6. Membranes will last indefinitely, depending on usage. Average replacement is 2-4 weeks. However, should the electrolyte be allowed to evaporate and an excessive amount of bubbles form under the membrane, or the membrane become damaged, thoroughly flush the reservoir with KCl and install a new membrane.
7. Also replace the membrane if erratic readings are observed or calibration is not stable.
8. "Home brew" electrolyte can be prepared by making a saturated solution of reagent grade KCl and distilled water and then diluting the solution to half strength with distilled water. Adding two drops of Kodak Photo Flo per 100 ml of solution assures good wetting of the sensor, but is not absolutely essential.
9. The gold cathode should always be bright and untarnished. If it is tarnished (which can result from contact with certain gases) or plated with silver (which can result from extended use with a loose or wrinkled membrane), return it to the factory for service or else clean it with the YSI 5680 Probe Cleaning Kit. Never use chemicals or any abrasive other than that supplied with this kit.
10. H₂S, SO₂, Halogens, Neon, Nitrous Oxide and CO are interfering gases. If you suspect erroneous readings, it may be necessary to determine if these are the cause. These gases have been tested for response.

100% Carbon Monoxide-Less than 1%	100% Helium-none
100% Carbon Dioxide-Around 1%	100% Nitrous Oxide-1/3 O ₂ response
100% Hydrogen-Less than 1%	100% Ethylene-none
100% Chlorine-2/3 O ₂ response	100% Nitric Oxide-1/3 O ₂ response

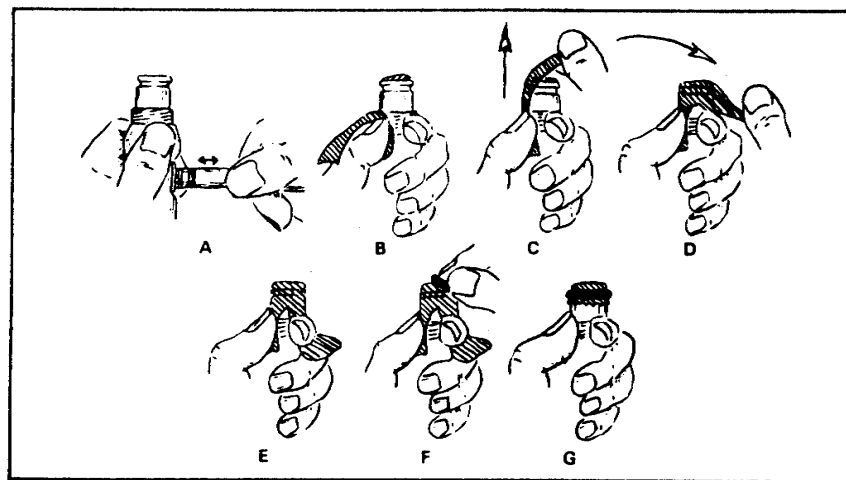
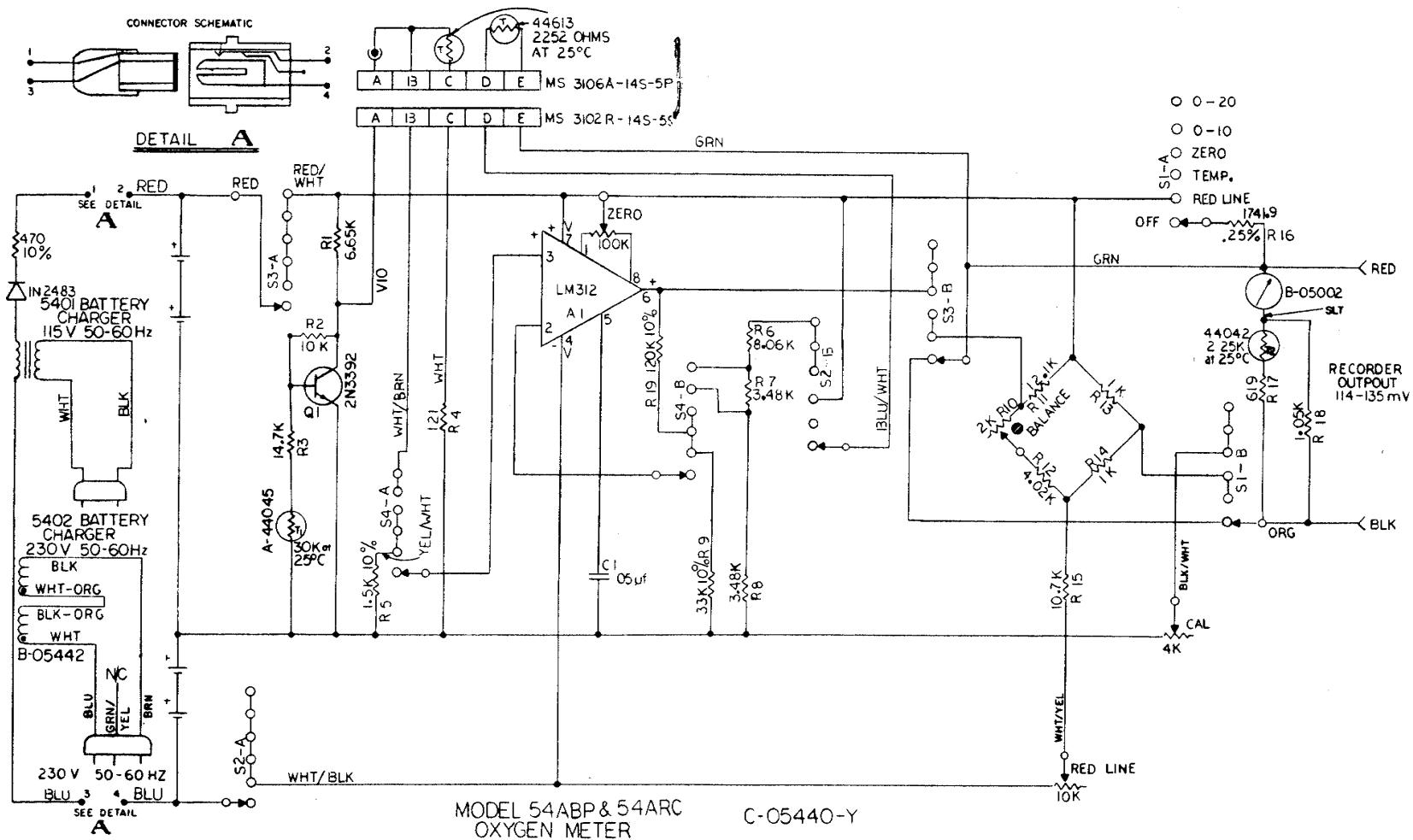

Figure 6



GENERAL NOTES:

1. ALL RESISTOR VALUES ARE IN OHMS; K=1,000, M=1,000,000. UNLESS OTHERWISE SPECIFIED, RESISTORS ARE 1/4W, 1% METAL FILM.
2. FOR 54ABP BATTERIES ARE 4 EA 1.5V PANASONIC UM-2N OR EQUIV.
FOR 54ARC BATTERIES ARE 4 EA 1.25V BURGESS CD6 OR EQUIV. NiCads.
3. BATTERY CHARGERS AND CONNECTOR APPLY TO 54ARC VERSION ONLY.
4. THE VALUES SHOWN ON THE SCHEMATIC MAY DIFFER FROM THOSE IN THE INSTRUMENT; IF SO, EITHER VALUE CAN BE USED FOR REPLACEMENT PURPOSES.

This schematic is representative only, and may be slightly different from the circuit in your instrument.

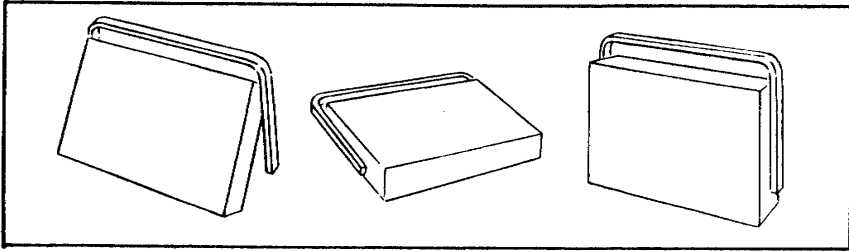

Figure 7

II. Preparing the Instrument

It is important that the instrument be placed in the intended operating position vertical, tilted, or on its back — before it is prepared for use and calibrated. (See Figure 7). Readjustment may be necessary when the instrument operating position is changed. After preparing the probe proceed as follows:

1. With switch in the OFF position, adjust the meter pointer to Zero with the screw in the center of the meter panel. Readjustment may be necessary if the instrument position is changed.
2. Switch to RED LINE and adjust the RED LINE knob until the meter needle aligns with the red mark at the 31°C position.
3. Switch to ZERO and adjust to zero with zero control knob.
4. Attach the prepared probe to the PROBE connector of the instrument and adjust the retaining ring finger tight.
5. Before calibrating allow 15 minutes for optimum probe stabilization. Repolarize whenever the instrument has been OFF or the probe has been disconnected.

III. Calibration

The operator has a choice of three calibration methods — Winkler Titration, Saturated Water, and Air. Experience has shown that air calibration is quite reliable, yet far simpler than the other two methods. The three methods are described in the following paragraphs.

Winkler Titration

1. Draw a volume of water from a common source and carefully divide into four samples. Determine the oxygen in three samples using the Winkler Titration technique and average the three values. If one of the values differs from the other 2 by more than 0.5 mg/l, discard that value and average the remaining two.
2. Place the probe in the fourth sample and stir.
3. Switch to desired mg/l range and adjust the CALIBRATION control to the average value determined in Step 1. Allow the probe to remain in the sample for at least two minutes before setting the calibration value, and leave in the sample for an additional 2 minutes to verify stability. (Readjust if necessary).

Saturated Water

1. Air saturate a volume of water (300-500 cc) by aerating or stirring for at least 15 minutes at a relatively constant temperature.

2. Place the probe in the sample and stir. Switch to TEMPERATURE. Refer to Calibration Table I for the mg/l value corresponding to the temperature.
3. Determine local altitude or the "true" atmospheric pressure (note that "true" atmospheric pressure is as read on a barometer. Weather Bureau reporting of atmospheric pressure is corrected to sea level). Using Calibration Table II determine the correction factor for your pressure or altitude.
4. Multiply the mg/l value from Table I by the correction factor from Table II to determine the corrected calibration value for your conditions.

EXAMPLE: Assume temperature = 21°C and altitude = 1000 feet. From Table I the calibration value for 21°C is 8.9 mg/l. From Table II the correction factor for 1000 feet is about 0.96. The corrected calibration value is $8.9 \text{ mg/l} \times 0.96 = 8.54 \text{ mg/l}$.

5. Switch to an appropriate mg/l range and adjust the CALIBRATE knob while stirring until the meter reads the corrected calibration value from Step 4. Leave the probe in the sample for two minutes to verify calibration stability. Readjust if necessary.

Air Calibration — Fresh Water

1. Place the probe in moist air. B.O.D. probes can be placed in partially filled (50 ml) B.O.D. bottles. Other probes can be placed in the YSI 5075A Calibration Chamber (refer to the following section describing CALIBRATION CHAMBER) or the small calibration bottle (the one with the hole in the bottom) along with a few drops of water. The probe can also be wrapped loosely in a damp cloth taking care the cloth does not touch the membrane. Wait approximately 10 minutes for temperature stabilization. This may be done simultaneously while the probe is stabilizing.
2. Switch to TEMPERATURE and read. Refer to Table I — Solubility of Oxygen in Fresh Water, and determine calibration value.
3. Determine altitude or atmospheric correction factor using Table II.
4. Multiply the calibration value from Table I by the correction factor from Table II.

EXAMPLE: Assume temperature = 21°C and altitude = 1000 feet. From Table I the calibration value for 21°C is 8.9 mg/l. From Table II the correction factor for 1000 feet is about 0.96. Therefore, the corrected calibration value is $8.9 \text{ mg/l} \times 0.96 = 8.54 \text{ mg/l}$.

5. Switch to the appropriate mg/l range and adjust the CALIBRATE knob until the meter reads the corrected calibration value from Step 4. Wait two minutes to verify calibration stability.

Readjust if necessary.

Air Calibration — Sea Water

1. Place the probe in moist air. B.O.D. probes can be placed in partially filled (50 ml) B.O.D. bottles. Other probes can be placed in the YSI 5075A Calibration Chamber (refer to the following section describing Calibration Chamber) or the small storage bottle (the one with the hole in the bottom) along with a few drops of water. The probe can also be wrapped loosely in a damp cloth taking care the cloth does not touch the membrane. Wait approximately 10 minutes for temperature stabilization. This may be done simultaneously while the probe is polarizing.

- Switch to TEMPERATURE and read. Refer to Table III — Solubility of Oxygen in Sea Water, and determine calibration value.
- Switch to the appropriate mg/l range, and adjust the CALIBRATE knob until the meter reads the calibration value determined in Step 2. Wait 2 minutes to verify calibration stability. Readjust if necessary.

The probe is now calibrated and should hold this calibration value for many measurements. Calibration can be disturbed by physical shock, touching the membrane, or drying out of the electrolyte. Check calibration after each series of measurements and in time you will develop a realistic schedule for recalibration. For best results when not in use, follow the storage procedures recommended for the various probes described under OXYGEN PROBES AND EQUIPMENT. This will reduce drying out and the need to change membranes.

Calibration Chamber

The YSI 5075A Calibration Chamber is an accessory that helps obtain optimum calibration in the field and is also a useful tool for measuring at shallow depths (less than 4').

As shown in Figure (A), it consists of a 4-1/2 foot stainless steel tube (1) attached to the calibration chamber (2), the measuring ring (3), and two stoppers (4) and (5).

For calibration, insert the solid stopper (4) in the bottom of the calibration chamber (2). Push the oxygen probe (6) through the hollow stopper (5) as shown in Figure (B). Place the probe in the measuring ring, Figure (C), and immerse the probe in the sample to be measured for five minutes to thermally equilibrate the probe. Quickly transfer the probe to the calibration chamber (5) draining excess water from the chamber and shaking any excess droplets from

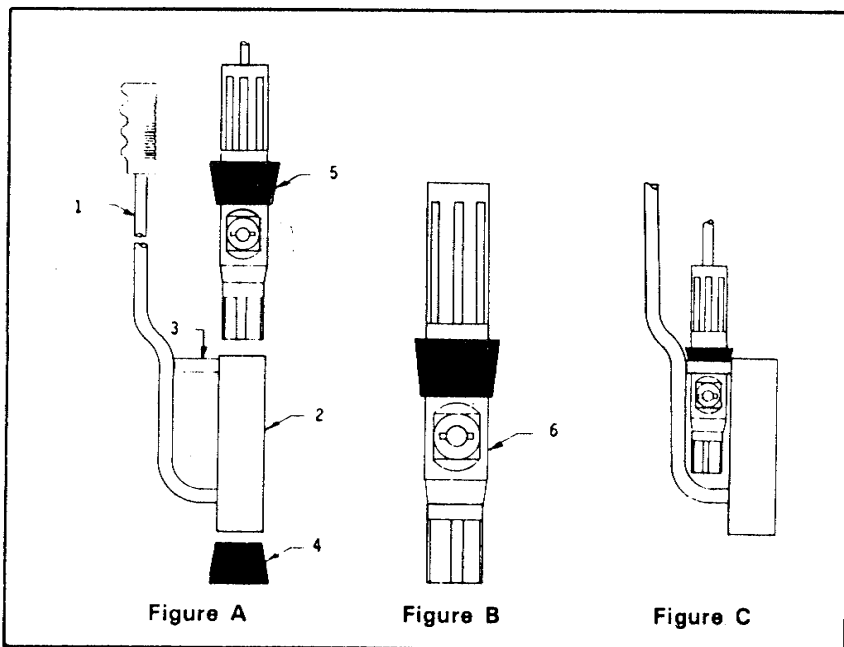

Figure 8

the probe membrane. For maximum accuracy, wet the inside of the calibration chamber with fresh water. This creates a 100% relative humidity environment for calibration. Place the chamber in the sample for an additional five minutes for final thermal equilibrium. Calibrate the probe as described in the air-calibration procedure. Keep the handle above water at all times.

After calibration, return the probe to the measurement ring for shallow measurements. Move the probe up and down, or horizontally, approximately one foot a second while measuring. In rapidly flowing streams (greater than 5'/second) install the probe in the measuring ring with the pressure compensating diaphragm towards the chamber.

IV. Dissolved Oxygen Measurement

With the instrument prepared for use and the probe calibrated, place the probe in the sample to be measured and provide stirring.

- Stirring for the YSI 5739 Probe can best be accomplished with a YSI submersible stirrer. If the submersible stirrer is not used, provide manual stirring by raising and lowering the probe about 1 ft. per second. If the 5075 Calibration Chamber is used, the entire chamber may be moved up and down in the water at about 1 ft. per second.
- The YSI 5720A has a built-in power driven stirrer.
- With the YSI 5750 sample stirring must be accomplished by other means such as with the use of a magnetic stirring bar.
- Allow sufficient time for probe to stabilize to sample temperature and dissolved oxygen.
- Read dissolved oxygen.

V. High Sensitivity Membrane

Use of high sensitivity .0005" membranes (YSI 5776) in place of standard .001" membrane (YSI 5775) is recommended when measurements are to be made consistently at low temperatures (less than 15°C). Calibration and readings will be made just as if the standard YSI 5775 Membrane was being used.

The YSI 5776 High Sensitivity Membranes can also be used in certain situations to increase sensitivity at temperatures about 15°C. The ranges thus become 0-5 and 0-10 mg/l. When calibration with high sensitivity membranes is attempted at temperatures greater than 15°C the selector switch must be set to 0-20 mg/l. Multiply the calculated calibration value by 2. For example: at 21°C and 1000 ft. altitude the calibration value would be 8.6 x 2 or 17.2. Remember the 0-10 and 0-20 mg/l ranges are now 0-5 and 0-10 mg/l, and all mg/l readings must be divided by 2 for a final reading. When operating in this manner accuracy will be degraded slightly.

VI. Recorder Output

Red and black recorder jacks are provided on the YSI Models 54ARC and 54ABP, if you wish to record data while measuring. The high terminal of the recorder is connected to the red tip jack and the low terminal to the black. Output of the YSI 54A at full scale is between 114 to 136 mV.

Use a 50K or higher input impedance recorder and operate it with the terminals ungrounded. The recorder should be operated with its terminals ungrounded. Calibration of the instrument should be checked after connection of the recorder.

Many recorders have an adjustable full scale sensitivity feature. When these recorders are used with the Model 54A, use the 100 millivolt range and adjust the full scale chart deflection when there is full scale meter deflection. Refer to the instruction book for the recorder. For recorders without this feature, a simple divider network as shown below can be constructed. This is adequate to adjust the signal for full scale chart and meter deflection on the 100 mV fixed range recorders.

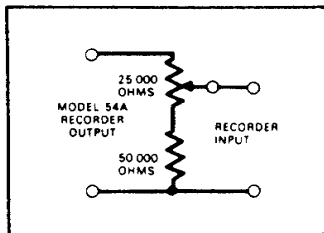

Figure 9

VIII. Calibration Tables

Table I shows the amount of oxygen in mg/L that is dissolved in air saturated fresh water at sea level (760 mmHg atmospheric pressure) as temperature varies from 0° to 45°C.

Table I - Solubility of Oxygen in Fresh Water

Temp °C	Solubility mg/L	Temp °C	Solubility mg/L	Temp °C	Solubility mg/L
0	14.62	17	9.67	34	7.07
1	14.22	18	9.47	35	6.95
2	13.83	19	9.28	36	6.84
3	13.46	20	9.09	37	6.73
4	13.11	21	8.92	38	6.62
5	12.77	22	8.74	39	6.52
6	12.45	23	8.58	40	6.41
7	12.14	24	8.42	41	6.31
8	11.84	25	8.26	42	6.21
9	11.56	26	8.11	43	6.12
10	11.29	27	7.97	44	6.02
11	11.03	28	7.83	45	5.93
12	10.78	29	7.69	46	5.84
13	10.54	30	7.56	47	5.74
14	10.31	31	7.43	48	5.65
15	10.08	32	7.31	49	5.56
16	9.87	33	7.18	50	5.47

Derived from 17th Edition, *Standard Methods for the Examination of Water and Wastewater*.

Table II shows the correction factor that should be used to compensate for the effects of variation in atmospheric pressure or altitude. Find true atmospheric pressure in the left hand column and read across to the right hand column to determine the correction factor. (Note that "true" atmospheric pressure is as read on a barometer. Weather Bureau reporting of atmospheric pressure is corrected to sea level.) If atmospheric pressure is unknown, the local altitude may be substituted. Select the altitude in the center column and read across to the right hand column for the correction factor.

Table II - Altitude Correction Factors

Pressure in			Altitude in		Correction Factor (%)
inches Hg	mm Hg	kPa	Feet	Meters	
30.23	768	102.3	-276	-84	101
29.92	760	101.3	0	0	100
29.33	745	99.3	558	170	98
28.74	730	97.3	1126	343	96
28.11	714	95.2	1703	519	94
27.52	699	93.2	2290	698	92
26.93	684	91.2	2887	880	90
26.34	669	89.2	3496	1066	88
25.75	654	87.1	4115	1254	86
25.12	638	85.1	4747	1447	84
24.53	623	83.1	5391	1643	82
23.94	608	81.1	6047	1843	80
23.35	593	79.0	6717	2047	78
22.76	578	77.0	7401	2256	76
22.13	562	75.0	8100	2469	74
21.54	547	73.0	8815	2687	72
20.94	532	70.9	9545	2909	70
20.35	517	68.9	10293	3137	68
19.76	502	66.9	11058	3371	66

Derived from 17th Edition, *Standard Methods for the Examination of Water and Wastewater*.

Table III - Solubility of Oxygen in Sea Water
(Chloride concentration 20,000 mg/L)

Temp. °C	Solubility mg/L	Temp. °C	Solubility mg/L	Temp. °C	Solubility mg/L
0	11.41	11	8.77	21	7.20
1	11.11	12	8.58	22	7.07
2	10.83	13	8.41	23	6.95
3	10.56	14	8.24	24	6.83
4	10.30	15	8.07	25	6.71
5	10.05	16	7.91	26	6.60
6	9.82	17	7.78	27	6.49
7	9.59	18	7.61	28	6.38
8	9.37	19	7.47	29	6.28
9	9.16	20	7.33	30	6.18
10	8.96				

Derived from 17th Edition, *Standard Methods for the Examination of Water and Wastewater*.

Correcting for Salinity

When measuring dissolved oxygen in water samples with a salinity or chlorinity between sea water and fresh water, calibrate the instrument for fresh water and make your measurements. Then correct the data according to the following formula:

FORMULA:

$$A = M \left[1.0 - \left(\frac{Cs/Co [Sf - So]}{Sf} \right) \right]$$

Where: A = Actual DO of sample. (mg/l dissolved O₂)

M = Measured DO with instrument

Co = Chlorinity of ocean water (20 o/oo Cl ion)

Cs = Chlorinity of sample (o/oo Cl ion)

Sf = DO of saturated fresh water at 760 mm pressure and at same temperature as sample (mg/l DO, obtain data from charts in instruction manual)

So = DO of saturated ocean water (20,000 mg/l Chloride ion) at 760 mm pressure and at same temperature as sample (mg/l DO, obtain data from instruction manual)

* NOTE: If salinity is used instead of chlorinity the ratio Cs/Co is computed using 36.11 o/oo for Co (salinity of ocean water), and the salinity of your sample of Cs.

EXAMPLE: Measured Data

DO = 4.1

Temp = 22°C

Salinity = 31 o/oo salinity

M = 4.1 mg/L DO, from data

Co = 36.11 o/oo salinity, from manual

Cs = 31.0 o/oo salinity, from data

Sf = 8.7 mg/L DO, from Table I in manual

So = 7.1 mg/L DO, from Table II in manual

$$A = 4.1 \left[1.0 - \frac{(31.0/36.11) (8.7 - 7.1)}{8.7} \right]$$

$$= 4.1 \left[1.0 - \frac{(.86) (1.6)}{8.7} \right]$$

$$= 4.1 \left[1.0 - \frac{1.38}{8.7} \right]$$

$$= 4.1 [1.0 - 0.158]$$

$$= 4.1 [0.842]$$

$$= 3.45 \text{ mg/L}$$

DISCUSSION OF MEASUREMENT ERRORS

There are three basic types of errors which can occur. Type I errors are related to limitations of the instrument design and tolerances of the instrument components. These are chiefly the meter linearity and resistor tolerances. Type II errors are due to basic probe accuracy tolerances, chiefly background signal, probe linearity, and variations in membrane temperature coefficient. Type III errors are related to the operator's ability to determine the conditions at the time of calibration. If calibration is performed against more accurately known conditions, Type III errors are appropriately reduced.

Individual Sources of Error

This description of sources of error can be used to attach a confidence to any particular reading of dissolved oxygen. The particular example given is for a near extreme set of conditions. As a generality, overall error is diminished when the probe and instrument are calibrated under conditions of temperature and dissolved oxygen which closely match the sample temperature and dissolved oxygen.

Type I

- A — is the error due to meter linearity
Error = +1% full scale of the measurement range.
- B — is the error due to tolerances in the instrument when transferring a reading from one range to another. Error = ±1% of the reading.

Type II

- A --- errors to to probe background current
Error = $1.0\% \left(1 - \left(\frac{\text{Cal. Value, mg/L}}{\text{Std. Cal. Value}} \right) \right) \times \text{Meter Reading in mg/L}$
- B --- errors due to probe non-linearity. Error = ±0.3% of reading
- C --- error caused by variability in the probe membrane temperature coefficient.
Error = zero, if readings are taken at the calibration temperature.
Error = ±1% of meter reading, if readings are taken within 5°C of the calibration temperature.
Error = ±3% of meter reading for all other conditions.

Type III

- A — errors due to the accuracy of the instrument thermometer when used to measure the exact probe temperature during calibration.
Error = ±1.5% of reading.
- B — errors due to the assumption of mean barometric pressure.
Daily variation is usually less than 1.7%.
Error = ±1.7% of reading.
- C — errors assume an ability to estimate altitude to within +500 ft. when computing the altitude correction factor.
Error = ±1.8% of reading.

- D errors consider the possibility of only 50% relative humidity when calibrating the probe. If the actual relative humidity is 50% instead of 100% the errors will be as follows:

Calibration Temperature ± C	Error in percent of reading
0	(-) 0.3
10	(-) 0.6
20	(-) 1.15
30	(-) 2.11
40	(-) 3.60

Example of a Typical Error Calculation

The example given presumes the air calibration technique. If calibration is done with air saturated water, the relative humidity consideration (III-D) is eliminated. If the Winkler calibration method is used, Type III errors are deleted and replaced by the uncertainty attributable to the overall Winkler determination.

Data: Instrument calibrated at 25°C, elevation estimated at 2000' ± 500', normal barometric pressure assumed, calibrated on 0-10 mg/l range at 7.8 mg/l, readings taken on 0-20 mg/l range at 10.5 mg/l at 8°C.

Type	Description	Calculations	Error in mg/L
IA	Linearity	= .01 x 10.5 mg/L	= .10
IB	Range Change	= .01 x 10.5 mg/L	= .10
IIA	Probe Background	= .01 x (1 - 7.8/9.07) x 10.5	= .01
IIB	Probe Linearity	= .003 x 10.5 mg/L	= .03
IIC	Temp. Compensation	= .03 x 10.5 mg/L	= .31
IIIA	Temp. Measurement	= .015 x 10.5 mg/L	= .16
IIIB	Pressure	= .017 x 10.5 mg/L	= .18
IIIC	Altitude	= .18 x 10.5 mg/L	= .19
IIID	Rel. Humidity	= .016 x 10.5 mg/L	= .17
	Maximum Possible Error		= 1.25 mg/L
	Probable Error		= .62 mg/L

Considering a statistical treatment of the probable error at any time for any instrument, it is likely that the actual error in any measurement will be about 1/2 of the possible error. In this case the probable error is about ±.5 mg/l out of a reading of 10.5 mg/l, or 4.8% of the reading.

INSTRUMENT BATTERIES

Battery replacement or recharging on the YSI Model 54A is indicated if the "red line" adjustment cannot be made or O₂ calibration cannot be achieved. (Warning: a faulty probe will also not permit O₂ calibration.)

To replace batteries remove the four screws holding the rear cover of the instrument. The four batteries will be found on the battery terminal board inside. CAUTION: disconnect battery charger on YSI Model 54ARC before removing cover.

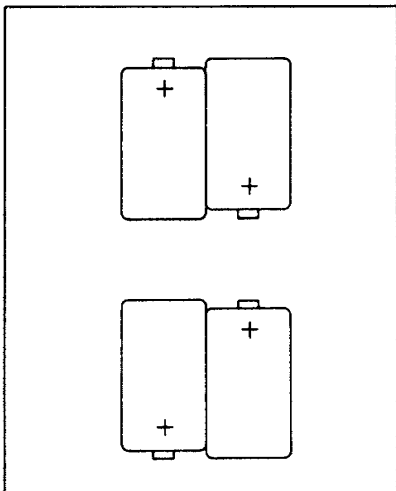

Figure 10

The YSI Model 54ARC contains four 1.25V Ni-Cd batteries (Burgess CD6 or equivalent). (See Figure 10). These batteries should be recharged when the instrument can no longer be red lined. Battery life should be three years or longer. Deeper discharge because of longer intervals between recharge will result in shorter battery life. The batteries should be recharged overnight, about 16 hours with the instrument off or 20 hours with the YSI Model 54ARC turned on.

Ni-cd AA

The YSI Model 54ABP contains four 1.5V carbon-zinc (Panasonic UM-2N or equivalent). The life of these batteries is 1000 hours. Replace batteries every six months to minimize danger of corrosion due to dead or leaky batteries.

Alkaline C

Battery holders are color coded. Positive (+ button) end of battery must go to red. (See Figure 10).

WARRANTY AND REPAIR

All YSI products carry a one-year warranty on workmanship and parts exclusive of batteries. Damage through accident, misuse, or tampering will be repaired at a nominal charge, if possible, when the item is returned to the factory or to an authorized YSI dealer.

If you are experiencing difficulty with any YSI product, it may be returned for repair, even if the warranty has expired. YSI maintains complete facilities for prompt servicing for all YSI products.

YELLOW SPRINGS INSTRUMENT CO., INC.
SERVICE DEPARTMENT
P.O. BOX 279
YELLOW SPRINGS, OHIO 45387, U.S.A.
PHONE: 513-767-7241

1067